

## Pallas

### *Round Conical*

#### **Description and Specification**

Pallas is a range of conical wooden lighting columns which is suitable for city centres, parks and street lighting. The simple conical profile of the Pallas range adds a touch of sophistication while the natural material offers a warmth and richness that is extremely difficult to duplicate with metallic lighting columns.

All shafts are manufactured from GL28h glued-laminated timber. The raw materials we use are harvested from sustainably managed, PEFC certified forests. All wood is treated with a water-based stain finish consisting of four protective coats, VOCs <100g/l. Cylindrical base and flush pole cap, in hot dip galvanised and powder coated S235 steel. The range is designed and developed according to Eurocode 5, standards ISO EN40 and ISO EN1995. A ZEP contract for CO2 compensation is available.



Glue Laminated Timber

---

#### **Finishing Options**



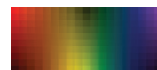







All wooden components are treated with a water-based stain finish consisting of four protective coats, VOCs <100g/l. Pole base and flush pole cap in hot dip galvanized and powder coated S235 steel. For more information contact your local Valmont representative.















RAL and AkzoNoble colour systems are available upon request.

# Pallas Round Conical









## Planted Root Dimensions

									
Height (m)	Top (mm)	Base (mm)	Height (mm)	Width (mm)	Position (mm)	Root (mm)	Steel Height (mm)	Mounting Arrangement	Projection (m)
4	100	168	400	85	500	800	1400	PT/SA/DA	1.2
5	100	168	400	85	500	800	1400	PT/SA/DA	1.2
6	100	168	400	85	500	1000	1400	PT/SA/DA	1.2
7	100	193	400	85	500	1200	1400	PT/SA/DA	1.2
8	100	193	400	85	500	1200	1400	PT/SA/DA	1.2
10	120	219	500	100	500	1500	1600	PT/SA/DA	1.2

## Flange Plated Dimensions

											
Height (m)	Top (mm)	Base (mm)	Height (mm)	Width (mm)	Position (mm)	Steel Height (mm)	Mounting Arrangement	Projection (m)	Width (mm)	Bolt Circle (mm)	Anchor Bolts
4	100	168	400	85	500	1400	PT/SA/DA	1.2	270	200	M14/16 x 300
5	100	168	400	85	500	1400	PT/SA/DA	1.2	270	200	M14/16 x 300
6	100	168	400	85	500	1400	PT/SA/DA	1.2	270	200	M14/16 x 300
7	100	193	400	85	500	1400	PT/SA/DA	1.2	400	300	M18/20 x 400
8	100	193	400	85	500	1400	PT/SA/DA	1.2	400	300	M18/20 x 400
10	120	219	500	100	500	1600	PT/SA/DA	1.2	400	300	M18/20 x 400

## Headload Capacity

																									
				22m/s		24m/s		26m/s		28m/s		30m/s		32m/s						34m/s		36m/s			
				II	I	II	I	III	II	I	III	II	I	III	II					I	I	I	M	T	
4	PT	0	25	3.52	2.82	2.94	2.36	2.82	2.5	2	2.43	2.14	1.71	2.1	1.86	1.49	1.84	1.64	1.3	1.16	1.02	11.20	2.89	0.5 x 0.9	1357
5	PT	0	25	2.25	1.81	1.87	1.51	1.91	1.58	1.27	1.64	1.35	1.1	1.42	1.18	0.95	1.24	1.02	0.83	0.73	0.64	10.39	2.38	0.5 x 0.8	1228
6	PT	0	25	1.52	1.24	1.25	1.02	1.35	1.06	0.85	1.16	0.89	0.73	0.99	0.78	0.63	0.86	0.68	0.55	0.47	0.41	10.01	2.11	0.5 x 0.8	608
7	PT	0	25	1.89	1.56	1.58	1.29	1.77	1.33	1.1	1.52	1.14	0.94	1.31	0.99	0.81	1.15	0.85	0.7	0.6	0.52	15.05	2.76	0.5 x 1	531
8	PT	0	25	1.42	1.16	1.17	0.96	1.35	0.97	0.81	1.15	0.83	0.68	0.98	0.71	0.58	0.84	0.61	0.49	0.41	0.36	14.86	2.62	0.5 x 1	517
10	PT	0	25	1.49	1.25	1.24	1.03	1.39	1.04	0.85	1.19	0.87	0.71	1.01	0.74	0.58	0.86	0.62	0.47	0.38	0.3	21.43	3.34	0.6 x 1.2	382

All dimensions and technical information given as an indication. Valmont reserves the right to make, without delay and without prior notice, the technical or aesthetic modifications that it deems necessary to improve the products of the Standard Collection.

\* Mounting Arrangement Abbreviations: PT = Post Top, SA = Single Arm, DA = Double Arm, QA = Quad Arm, FL = Floodlight, SE = Side Entry, CB = Crossbar, CR = Crown, PF = Platform, OT = Other  
 \* Speeds given are basic 10 minute mean wind speeds in 2m/s increments, if national wind speeds lie between these figures please interpret using linear interpolation.

\* **M** = Bending moment at baseplate, **T** = Shear force at baseplate.